

See discussions, stats, and author profiles for this publication at: <https://www.researchgate.net/publication/277123868>

New technological procedure for sustainable processing of mining technological waste

Article in *Rudarski radovi Bor* · January 2012

CITATIONS

0

READS

73

3 authors, including:



Zoran Štirbanović

Technical Faculty in Bor

1 PUBLICATION 0 CITATIONS

SEE PROFILE



Jovica M. Sokolović

University of Belgrade, Technical Faculty in Bor

20 PUBLICATIONS 124 CITATIONS

SEE PROFILE

Some of the authors of this publication are also working on these related projects:



XII International Symposium on Recycling Technologies and Sustainable Development [View project](#)



XIV International Mineral Processing and Recycling Conference (IMPRC 2021) [View project](#)

UDK: 622.7:666.952:658.567(045)=861

Rodoljub D. Stanojlović, Zoran M. Štirbanović*, Jovica M. Sokolović**

NOVI TEHNOLOŠKI POSTUPAK ZA ODRŽIVU PRERADU RUDARSKOG TEHNOGENOG OTPADA**

Izvod

Rezultati istraživanja pokazuju, tehnološku mogućnost i ekonomsku opravdanost zajedničke prerade dve tehnogene otpadne sirovine koje nastaju u procesima prerade rude bakra. Šljaka plamene peći Topionice bakra u Boru i flotacijska jalovina Rudnika bakra Bor, Srbija su dve tehnogene otpadne sirovine skladirane na deponijama i u permanentnom nastajanju. One predstavljaju velike zagađivače životne sredine, a shodno sadržaju korisnih komponenti u istim, i potencijalne sirovinske resurse. Zbog specifičnih fizičko-hemijskih i mineraloških karakteristika pojedinačna prerada ovih otpadnih sirovina ne garantuje profitabilnu delatnost. Zajedničku preradu topioničke šljake i stare flotacijske jalovine u masenom odnosu 90 % šljake i 10 % flotacijske jalovine, u originalnom tehnološkom postupku povećava se iskorišćenje bakra u procesu flotiranja za oko 15 %, istovremeno povećava efikasnost procesa mlevenja i klasiranja, time smanjuje potrošnju energije za 10-15 %, čineći da prerada ovih otpadnih sirovina, pored ekološkog, ima i pozitivan ekonomski efekat.

Ključne reči: *topionička šljaka, flotacijska jalovina, tehnogeni otpadi, flotacija, iskorišćenje bakra*

UVOD

Rudarsko-topioničarski basen Bor, u složenim tehnologijama proizvodnje bakra, od eksploatacije do elektrolitičkog prečišćavanja, produkuje nekolino desetina različitih, zagađujućih, tehnogenih otpadnih

sirovina [1]. Veći broj istih, u gasovitom, tečnom ili čvrstom stanju, sadrže značajne koncentracije korisnih komponentata, koje se, uz primenu savremenih tehnologija mogu valorizovati. Rezultati istraživanja

* Univerzitet u Beogradu, Tehnički fakultet u Boru
Katedra za mineralne i reciklažne tehnologije

** U ovom radu su prikazani rezultati projekata TR 33038 „Usavršavanje tehnologija eksploatacije i prerade rude bakra sa monitoringom životne i radne sredine u RTB Bor Grupa“ i TR 33007 „Implementacija savremenijih tehničko-tehnoloških i ekoloških rešenja u postojećim proizvodnim sistemima Rudnika bakra Bor i Rudnika bakra Majdanpek“ finansiranih od strane Ministarstva za prosvetu i nauku Republike Srbije. Autori se zahvaljuju pomenutom Ministarstvu.

prerade topioničke šljake, najzastupljenijeg tehnogenog otpada u metalurgiji bakra, upućuju na tehnološku mogućnost prerade [2,3]. Zbog povećane otpornosti prema usitnjavanju, povećane gustine i odsustva aluminata [4-7], pulpa formirana od topioničke šljake poseduje smanjenu viskoznost i stabilitet. Ove karakteristike topioničke šljake i pulpe formirane od iste, uslovljavaju brzu sedimentaciju čvrste faze, što negativno utiče na efikasnost najznačajnijih procesa prerade, mlevenje i klasiranje, kao i proces flotacijske koncentracije. Povećana potrošnja energije u procesu mlevenja, odnosno povećanje troškova prerade i smanjeno iskorišćenje korisnih komponenti u procesu flotiranja, dovode u pitanje ekonomičnosti prerade ovog tehnogenog otpada.

Istraživanja poboljšanja viskoziteta i stabilnosti pulpe, dodavanjem flotacijske jalovine u procesu mlevenja šljake trebalo bi da daju pozitivne rezultate. Primena flotacijske jalovine, najzastupljenijeg tehnogenog otpada i najvećeg zagađivača životne sredine u procesima prerade rude bakra, će poboljšati karakteristike pulpe, a time i efikasnost najznačajnijih faza procesa. Zahvaljujući manjoj gustini čvrste faze flotacijske jalovine, kao i prisustvu finozičnih aluminata i aluminosilikata, pulpa formirana od definisanog masenog odnosa navedenih otpadnih sirovina, ima povećanu viskoznost i stabilitet što uslovljava veću efikasnost procesa mlevenja i klasiranja, odnosno manju potrošnju energije u procesu prerade, kao i povećano iskorišćenje korisnih komponenti u procesu flotiranja. Povećano iskorišćenje bakra iz mešavine topioničke šljake i flotacijske jalovine moglo bi biti rezultat kako većeg iskorišćenja bakra iz šljake zbog boljih hidrodinamičkih uslova flotiranja čestica veće krupnoće i gustine, tako i dodatnog iskorišćenja bakra sadržanog u flotacijskoj jalovini. Veća viskoznost pulpe pozitivno utiče na efikasnost mlevenja u mlinu sa

kuglama, zbog boljeg prijanjanja sirovine za meljuća tela, a povećana efikasnost hidraulične klasifikacije u hidrociklonu, kao posledica veće stabilnosti pulpe smanjuje nepotrebno vraćanje dovoljno usitnjenih čestica za proces flotiranja, kroz pesak hidrociklona na ponovno mlevenje u mlinu sa kuglama.

Smanjenje cirkulativne šarže do optimalne granice, odnosno smanjeno učešće dovoljno usitnjenim česticama u pesku hidrociklona, ima višestruki tehnološki značaj. Pored povećanja kapaciteta i smanjenja potrošnje energije u procesu mlevenja, kao najvećeg troška u procesu prerade, manje preusitnjavanje čestica korisnih komponenti uslovljava veće iskorišćenje istih u procesu flotiranja.

Pozitivni efekti primene nove tehnologije, zajedničke prerade topioničke šljake i flotacijske jalovine, izraženi kroz smanjenje troškova prerade i povećano iskorišćenje korisnih komponenti, omogućavaju profitabilnu delatnost i ekonomsku održivost zaštite životne sredine.

EKSPERIMENTALNI DEO

Eksperimentalna istraživanja su sadržana u dve faze. U prvoj fazi su vršena laboratorijska ispitivanja karakteristika topioničke šljake i flotacijske jalovine i pulpe formirane od istih, značajnih za predviđene postupke prerade. U drugoj fazi eksperimenata izvedeni su paralelni opiti flotacijske koncentracije bakra iz topioničke šljake, i mešavine šljake i flotacijske jalovine, čiji rezultati treba da potvrde predhodna teoretska razmatranja o tehnološkoj opravdanosti zajedničke prerade ovih tehnogenih otpadnih sirovina.

Sva laboratorijska ispitivanja vršena su u akreditovanim i licenciranim laboratorijama Tehničkog fakulteta u Boru i Institutu za rudarstvo i metalurgiju Bor.

Mikroskopska i mineraloška ispitivanja vršena su na mikroskopu tipa Carl Zeiss-Jena "JENAPOL-U".

Hemijske analize uzoraka vršene su primenom različitih analitičkih metoda (tabela 2).

Karakteristike topioničke šljake

Za odabrani proces koncentracije bakra iz topioničke šljake, flotacijsku koncentraciju, od posebnog značaja su mineraloški i hemijski sastav sirovine. U tabelama 1. i 2. prikazane su ove karakteristike šljake.

Tabela 1. Mineraloški sastav topioničke šljake

Minerali	Zastupljenost (%)
Fajalit	60,00
Magnetit	30,00
Bornit	6,50
Halkopirit	1,50
Elem.bakar	0,50
Bakrenac	0,30
Hrizokola	0,15
Kovelin	0,05
Pirit	1,00
Σ	100,00

Tabela 2. Hemijski sastav topioničke šljake

Elementi	Sadržaj (%)	Analitička metoda
Fe _{uk}	37,05	VT
SiO ₂	32,77	G
Fe ₃ O ₄	9,68	A-Fe 304
Al ₂ O ₃	4,86	ICP-AES
Fe u Fe ₂ O ₃	3,02	R
S	0,81	G
Ca	3,21	AAS
Mg	0,62	AAS
Cu _{uk}	0,84	SF
Cu _{elem}	0,38	G
Cu _{sul}	0,30	R
Cu _{ox}	0,16	PO
Ag	3,3 g/t	FA
Au	0,5 g/t	FA

Mineraloški i hemijski sastav topioničke šljake potvrđuju mogućnost primene flotacijske koncentracije kao metode za koncentraciju korisnih komponenti. Sadržaj bakra od 0,84 % i plemenitih metala, zlata od 0,5 g/t i srebra od 3,3 g/t, potvrđuje konstataciju da ovaj tehnogeni otpad sadrži 2-3 puta veću koncentraciju navedenih korisnih komponenti od sadržaja istih u primarnim rudama bakra, oko 0,25 - 0,35 % Cu, koje se sada eksploatišu. Ova činjenica upućuje na zaključak da ovaj tehnogeni otpad predstavlja sirovinski resurs i opravdava istraživanja mogućnosti prerade istog.

Gustina topioničke šljake određena staklenim piknometrom iznosi $\rho_s \approx 3500 \text{ kg/m}^3$. Sama činjenica da je gustina ovog tehnogenog otpada za oko 500 - 700 kg/m^3 veća od gustine rude bakra upućuje na zaključak o većoj brzini sedimentacije čestica šljake u pulpi u odnosu na brzinu sedimentacije čestica rude bakra iste krupnoće.

Meljivost, odnosno otpornost prema usitnjavanju, kinetika mlevenja i garnulometrijski sastav su fizičke karakteristike sirovine od kojih u najvećoj meri zavise troškovi prerade iste.

Bond-ov indeks meljivosti u mlinu sa kuglama za topioničku šljaku iznosi $W_i = 31 \text{ kWh/t}$, što je oko 2 puta veća vrednost od istog za rudu bakra. Ova činjenica upućuje na očekivanu veliku potrošnju energije u procesu usitnjavanja. Na slici 1, dijagramima su prikazane kinetike mlevenja topioničke šljake i rude bakra, gde se jasno uočava višestruko duže vreme mlevenja topioničke šljake u odnosu na rudu bakra za postizanje iste finoće proizvoda mlevenja.

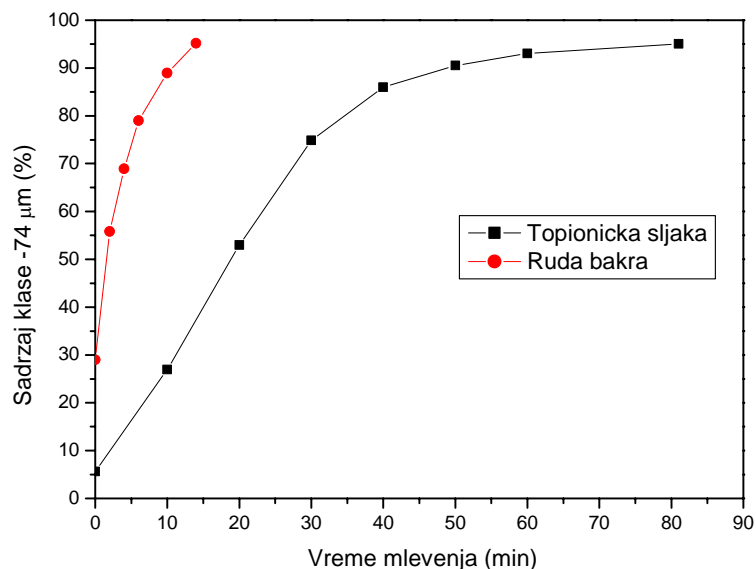

Sl. 1. Efikasnost mlevenja topioničke sljake i rude bakra

Rezultati istraživanja nedvosmisleno ukazuju na veliku otpornost usitnjavanja ovog tehnogenog otpada, što potvrđuje predhodnu konstataciju o velikoj potrošnji energije u procesu usitnjavanja, a time i povećanim troškovima prerade.

Karakteristike flotacijske jalovine

Istraživanja su vršena na "staroj" flotacijskoj jalovini produkovanj u procesu flotiranja rude bakra u prvoj polovini prošlog veka. Za ovu tehnogenu otpadnu sirovinu smo se opredelili s obzirom na povećani sadržaj korisnih komponenti u istoj, 0,15 – 0,4% Cu, uslovljen visokim sadržajem bakra u rudi koje je u tom periodu prerađivana oko 2,5-3% Cu, kao i efikasnošću tada primenjivane tehnologije flotacijske koncentracije.

Mineraloški sastavi flotacijske jalovine određeni na uzorcima iz različitih dubina

starog flotacijskog jalovišta prikazani su u tabeli 3, a hemijski sastavi jalovine određeni na uzorcima sa različitih, za flotaciju karakterističnih delova deponije, prikazani su u tabeli 4.

Tabela 3. Mineraloški sastavi uzoraka stare flotacijske jalovine

Minerali	Zastupljenost (%)	
	Uzorak 1 (0-16 m)	Uzorak (16-40m)
Halkopirit	0,16	0,12
Kovelin	0,03	0,11
Energit	0,01	0,02
Halkozin	0,01	0,01
Bornit	U tragu	0,01
Azurit	U tragu	0,03
Kuprit	0,01	0,04
Pirit	14,27	22,20
Minerali jalovine	80,63	71,96
Ostalo	4,88	5,50
Σ	100,00	100,00

Tabela 4. *Hemijski sastavi uzoraka stare flotacijske jalovine [3]*

Komponenta	Brana jalovišta	Unutrašnjost jalovišta	Analit. metoda
	Zastupljenost (%) (g/t)*	Zastupljenost (%) (g/t)*	
Cu _{ak}	0,155	0,370	
Cu _{ox}	0,033	0,120	
Cu _{sulf.}	0,122	0,250	
S	9,870	12,260	
Fe	8,860	10,270	
SiO ₂	58,030	59,710	
Al ₂ O ₃	12,040	12,630	
Au	0,300*	0,600	
Ag	2,140*	1,300	

Rezultati istraživanja pokazuju da je u jalovini sadržana značajna koncentracija korisnih komponenti u mineraloškom obliku pogodnom za primenu procesa flotiranja.

Tabela 5. *Vrednosti gustine uzoraka stare flotacijske jalovine [3]*

Flotacijska jalovina	Uzorak 1 (brana jalovišta)	Uzorak 2 (centralni deo jalovišta)	Uzorak 3 (obodni deo jalovišta)	Kompozitni uzorak
ρ (kg/m ³)	2 650	3 070	2 814	2 844

Znatno manja gustina flotacijske jalovine od gustine topioničke šljake uslovljena je različitim mineraloškim i hemijskim sastavom istih. Dok u topioničkoj šljaci dominantno učešće imaju fero-silikati većih gustina, cca 3700-3900 kg/m³, dotle u flotacijskoj jalovini najveće učešće imaju alumo-silikati znatno manjih gustina, oko 2500-2600 kg/m³.

Otpornost prema usitnjavanju finoznog materijala flotacijske jalovine nije moguće određivati standardnom Bond-ovom meto-

Međutim, shodno osnovnom razlogu korišćenja jalovine u procesu prerade topioničke šljake, a ista je poboljšanje karakteristika pulpe, odnosno povećanje viskoznosti i stabilneta do optimalnih vrednosti, od većeg značaja su fizičke karakteristike ovog tehnogenog otpada.

Gustina flotacijske jalovine određena je na većem broju uzoraka uzorkovanim na različitim mestima flotacijskog jalovišta. Potreba uzimanja uzoraka sa više različitih mesta flotacijskog jalovišta, od brane do plaže istog, uslovljena je načinom formiranja flotacijskog jalovišta i distribucije peska i preliva hidrociklona. Vrednosti gustine pojedinih uzoraka kao i srednja gustina flotacijske jalovine koja je korišćena u daljim istraživanjima date su u tabeli 5.

dom, međutim, ista se može poistovetiti sa otpornošću prema usitnjavanja primarne rude bakra, koja je za prerađivanu rudu u tom periodu iznosila od 10 – 15 kWh/t.

Shodno praktičnoj primeni rezultata istraživanja, a ista je zajednička prerada topioničke šljake i flotacijske jalovine, koja započinje mlevenjem mešavine, na slici 2, dijagramima su prikazane uporedne vrednosti kinetike mlevenja ova dva tehnogena otpada sa realnim – industrijskim početnim krupnoćama materijala.

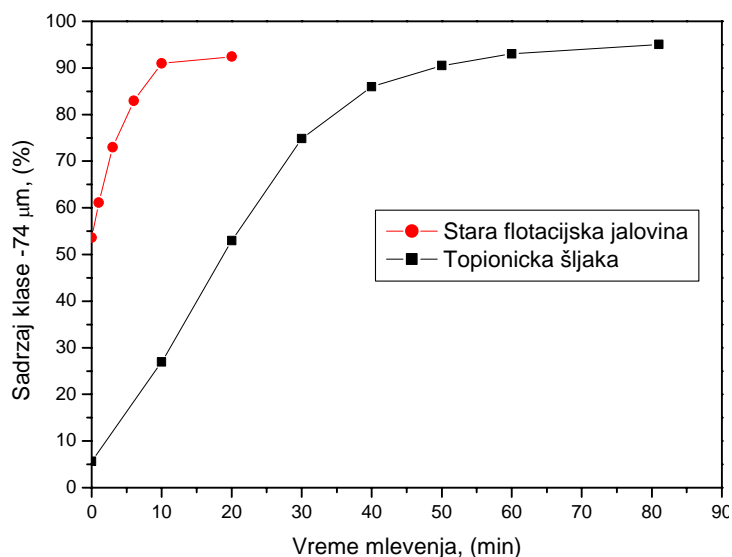

SI. 2. Efikasnost mlevenja topioničke šljake i stare flotacijske jalovine realnih početnih krupnoća

Znatno kraće vreme potrebno za ostvarivanje određene finoće proizvoda mlevenja flotacijske jalovine u odnosu na vreme potrebno za ostvarivanje iste finoće mlevenja topioničke šljake, upućuju na logičan zaključak o očekivanoj boljoj meljivosti mešavine ova dva tehnogena otpada u odnosu na meljivost čiste topioničke šljake.

EKSPERIMENTI MLEVENJA TOPIONIČKE ŠLJAKE I MEŠAVINE TOPIONIČKE ŠLJAKE I FLOTACIJSKE JALOVINE

Istraživanja meljivosti sirovina izvršena su postupkom mokrog mlevenja u mlinu sa kuglama. U prvoj fazi istraživanja izvedene su tri serije laboratorijskih opita, na topioničkoj šljaci i mešavini topioničke šljake i stare flotacijske jalovine u određenim masenim odnosima,

sa ciljem definisanja efikasnosti procesa mlevenja pojedinih uzoraka.

Druga faza istraživanja odnosila se na ispitivanje uticaja gustine pulpe, odnosno odnosa Č:T, na efikasnost procesa mlevenja u mlinu sa kuglama. Opiti su izvedeni na topioničkoj šljaci, kao i na mešavinama topioničke šljake i stare flotacijske jalovine definisanih masenih odnosa.

Oprema korišćena u eksperimentima

Opiti su izvedeni u laboratorijskom mlinu tipa „Denver“, pri sledećim tehničko-tehnološkim uslovima:

- karakteristike mlina
 - zapremina mlina: 13,8 l
 - masa šarže: 10,5 kg
 - broj obrtaja 56 min⁻¹
 - dimenzije mlina: DxL=370x130 mm
 - granulometrijski sastav meljuće šarže kugli

Tabela 6. Granulometrijski sastav šarže meljućih kugli

Krupnoća kugli (mm)	Masa (%)	D (%)
+50	15,30	100,00
-50+40	43,99	84,70
-40+30	27,64	40,71
-30+0	13,07	13,07
	100,00	-

- karakteristike mlina karakteristike sirovine
 - izdrobljena šljaka do GGK – 3,327 mm
 - flotacijska jalovina GGK – 0,833mm sa procentualnim učešćem 5% i 10%

Tehnološki režim laboratoriskih opita mlevenja

Svi eksperimenti su izvodjeni pri pret-hodno definisanim režimom opita mlevenja koji podrazumevaju:

- masa čvrstog u opitu mlevenja $m=1,0$ kg
- sadržaj čvrstog u pulpi u prvoj fazi istraživanja je $p=75\%$
- sadržaj čvrstog u pulpi u drugoj fazi istraživanja je $p=70-80\%$
- koeficijent punjenja mlina šaržom $\varphi=15\%$

Rezultati istraživanja

Efikasnost mlevenja topioničke šljake i mešavine topioničke šljake i stare flotacijske jalovine u definisanim masenim odnosima prikazana je na dijagramima na slici 3.

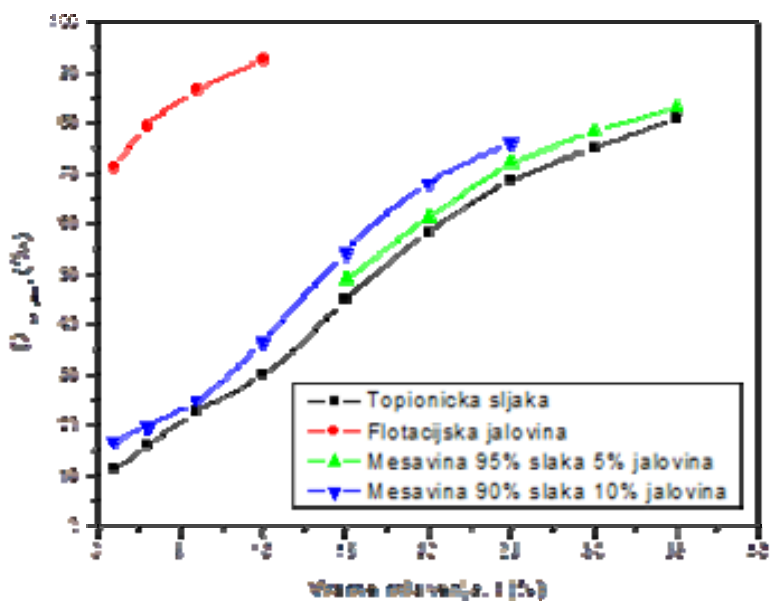

Sl. 3. Efikasnost mlevenja sirovine u mlinu sa kuglama

Na slici 4, dijagramom je prikazana zavisnost efikasnosti procesa mlevenja u mlinu sa kuglama od gustine pulpe,

odnosno odnosa Č:T, pri mlevenju topioničke šljake i mešavine čljake i stare flotacijske jalovine u trajanju od 20 minuta.

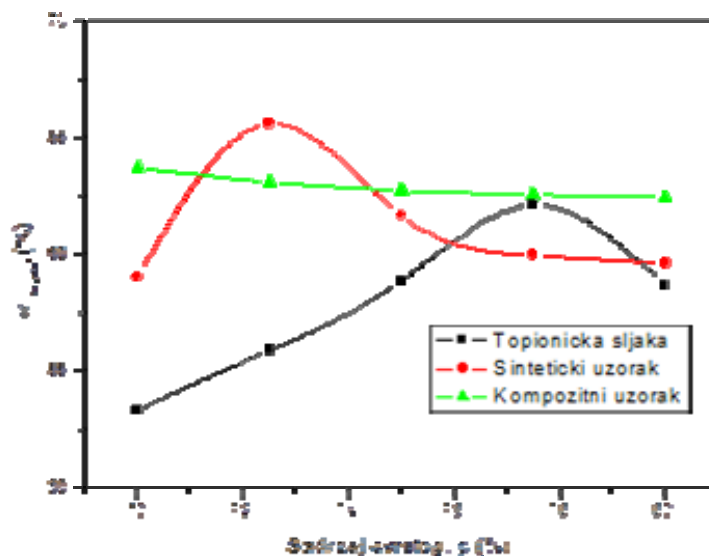

Sl. 4. Efikasnost mlevenja sirovine u funkciji gustine pulpe

Rezultati istraživanja efikasnosti mlevenja topioničke šljake i mešavine šljake i flotacijske jalovine u različitim masenim odnosima, prikazani dijagramima na slici 3, pokazuju pretpostavku o pozitivnom uticaju flotacijske jalovine, odnosno prisustvu aluminata na bolju efikasnost mlevenja. Za ostvarivanje finoće proizvoda mlevenja mešavine šljake i flotacijske jalovine od 60 % klase - 0,074 mm, potrebno je 7 % kraće vreme mlevenja za mešavinu 95 % šljake i 5 % jalovine, odnosno 18 % za mešavinu 90 % šljake i 10 % jalovine, u odnosu na isto vreme potrebno za mlevenje topioničke šljake, čime se vrši adekvatna ušteda energije. Različiti uticaj sadržaja čvrstog u pulpi, kao i različite vrednosti istog pokazatelja pri kojem se ostvaruju najbolji efekti mlevenja topioničke šljake i mešavina iste sa flotacijskom jalovinom, potvrđuju konsta-

taciju o pozitivnom uticaju aluminata na efikasnost mlevenja.

EKSPERIMENTI ODREĐIVANJA STABILITETA PULPE

Istraživanja uticaja flotacijske jalovine na stabilitet pulpe formirane od topioničke šljake vršena su paralelnim optima merenja brzine sedimentacije, odnosno visine istaložene čvrste faze u menzuri, u pulpama formiranim od topioničke šljake i mešavina različitih masenih odnosa šljake i flotacijske jalovine.

Oprema korišćena u eksperimentima

Opiti su izvođeni na indentičnoj opremi, što podrazumeva staklenu menzuru od 1000 ml i mehaničku mešalicu tipa TEHNICA ŽELEZNIKI UM 405.

Tehnološki režim izvođenja opita

Ekperimenti su izvođeni na sobnoj temperaturi od 20⁰ C, na uzorcima iste finoće proizvoda mlevenja, 60 % učešća klase – 0,074 mm, kao i istom odnosu čvrste i tečne faze 30% Č, sa konstantnim brojem obrtaja mešalice, 1000 o/min i pH vrednosti pulpe 8.

Rezultati istraživanja

Rezultati istraživanja brzine taloženja čvrste faze u pulpi formiranoj od topioničke šljake i mešavina šljake i flotacijske jalovine u različitim masenim odnosima, prikazani su dijagramima na slici 5.

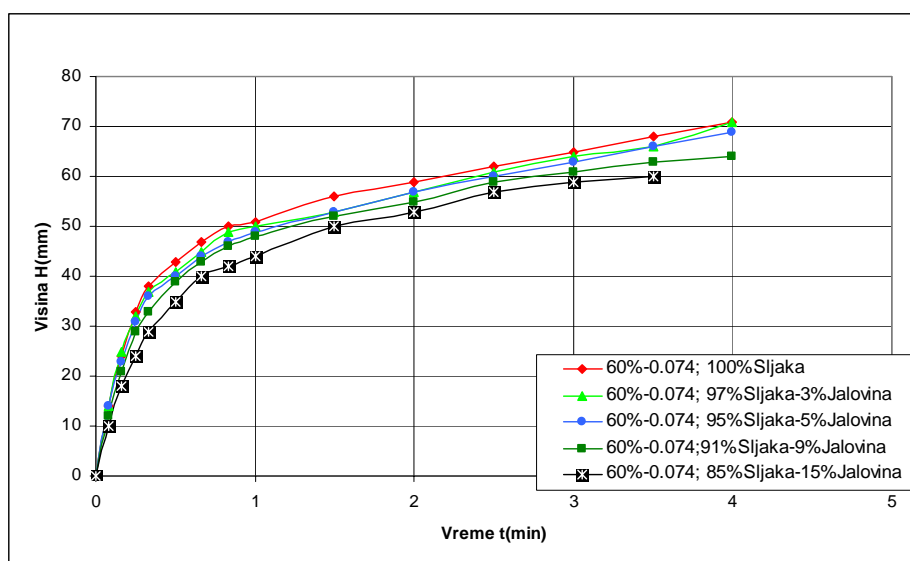

Sl. 5. Zavisnost visine formiranog taloga od vremena taloženja topioničke šljake, bez i sa dodatkom jalovine

Zbog specifičnosti procesa flotiranja koji zahteva održavanje čvrste faze pulpe u disperznom stanju, odnosno obezbeđivanju hidrodinamičkih uslova koji omogućuju taloženje čvrste faze, ekperimenti određivanja stabiliteta pulpe formirane od topioničke šljake i mešavina iste sa flotacijskom jalovinom izvođeni su merenjem visine istaložene čvrste faze u funkciji vremena taloženja. Rezultati istraživanja prikazani dijagramima na slici 5, nedvosmisleno potvrđuju teoretsku pretpostavku da će prisustvo flotacijske jalovine, odnosno finoznih aluminata i

alumosilikata u pulpi topioničke šljake usloviti povećanu stabilnost iste. Povećanje dužine vremena potrebnog da se u statičkim uslovima procesa sedimentiranja istaloži ista visina taloga čvrste faze u svim vremenskim intervalima i za sve visine istaložene čvrste faze sa sigurnošću potvrđuju pozitivan uticaj flotacijske jalovine na stabilnost pulpe.

Očekivane posledice ove pojave su pre svega veće efikasnosti procesa hidraulične klasifikacije u hidrociklonu i flotacijske koncentracije sa svim prethodno objašnjenim pozitivnim efektima.

EKSPERIMENTI FLOTIRANJA

Istraživanja procesa flotacijske koncentracije bakra iz topioničke šljake vršena su u pet serija laboratorijskih opita.

Pri istom, prethodno utvrđenom optimalnom tehnološkom režimu, laboratorijski opiti flotacijske koncentracije vršeni su na uzorku topioničke šljake i četiri uzorka mešavine šljake i stare flotacijske jalovine u različitim masenim odnosima.

Oprema korišćena u eksperimentima

Eksperimenti flotiranja vršeni su u laboratorijskoj flotacionoj mašini tipa „DENVER DR-12“ zapremine ćelije 2,6 l. Broj obrtaja rotora je 1600 o/min, sa samousisanom zapreminom vazduha 260 l/min, odnosno 4,33 l/s.

Kontrola pH vršena je pH metrom tipa MA 5705, Iskra Kranj, sa kombinovanom elektrodom, tip SENTIX 50.

Tehnološki režim opita flotiranja

Tehnološka mogućnost zajedničke prerade tehnogenih otpada, topioničke šljake i flotacijske jalovine eksplicitno se može povrditi rezultatima koncentracije korisnih komponenti iz istih, kinetikom procesa flotiranja i tehnološkim iskorišćenjem korisnih komponenti.

Efekat uticaja flotacijske jalovine na tehnološke pokazatelje procesa flotiranja topioničke šljake biće sagledani upoređivanjem rezultata paralelnih laboratorijskih opita flotiranja topioničke šljake i mešavina šljake i flotacijske jalovine, u različitim masenim odnosima, pri indentičnoj šemi i režimu flotiranja.

Šema i režim laboratorijskih opita osnovnog flotiranja, prikazani na slici 6, definisani su na osnovu obimnih istraživanja optimizacije parametara procesa.

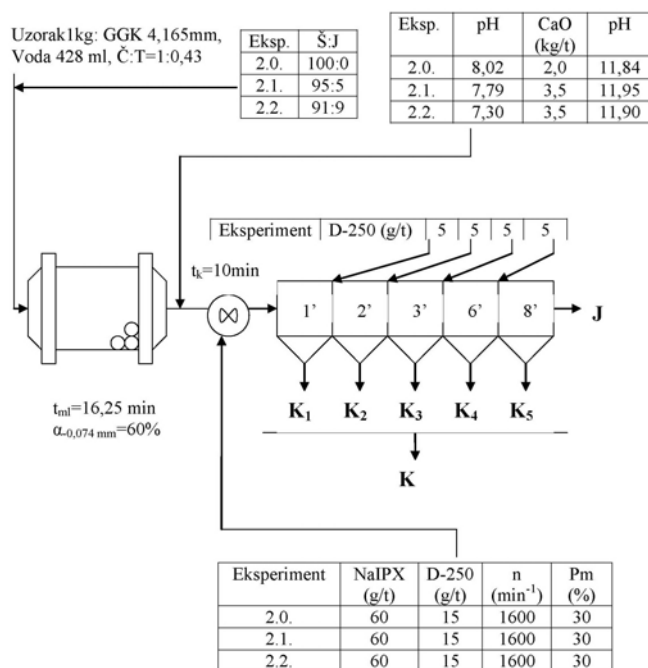

Sl. 6. Tehnološka šema izvodjenja eksperimenata

Rezultati istraživanja

Na slici 7, dijagramima su prikazane kinetike flotacijske koncentracije bakra iz topioničke šljake i mešavina šljake i flotacijske jalovine različitih masenih odnosa, za svaki laboratorijski opit posebno.

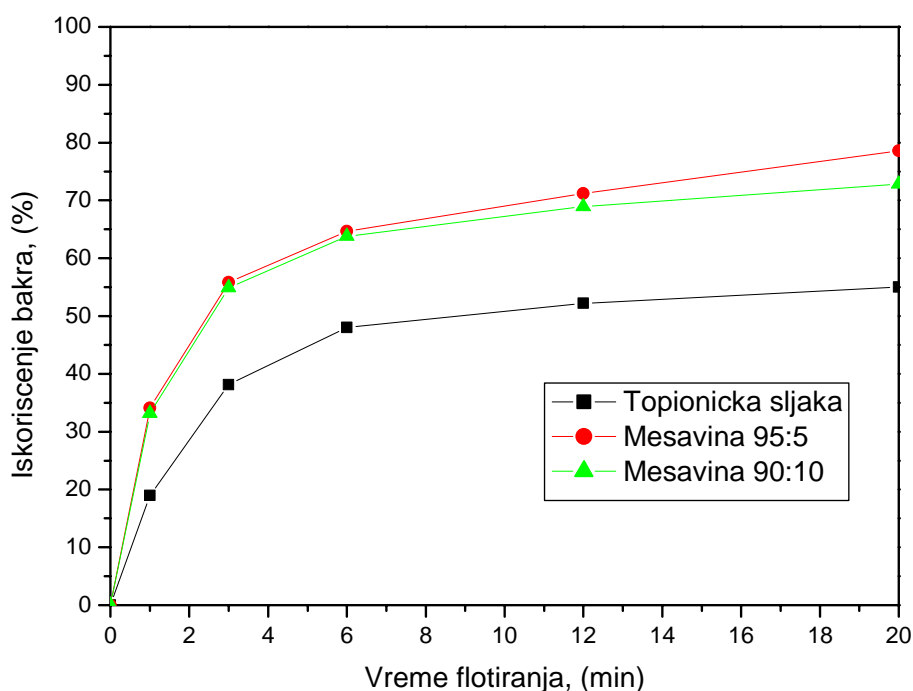

Sl. 7. Kinetike flotiranja topioničke šljake i mešavina šljake i jalovine u odnosima 95:5 i 90:10

Rezultati istraživanja kinetike flotiranja bakra iz topioničke šljake i mešavina šljake i flotacijske jalovine, prikazani na slici 7, potvrđuju pozitivan uticaj stabilnosti i viskoziteta pulpe na iskorišćenje bakra. Razlika u iskorišćenju osnovne korisne komponente, bakra za oko 17%, odnosno 24%, pri opitu flotiranja u trajanju od 20 minuta su iznad svih

očekivanja. Neophodno je istaći, da su uzrok povećanom iskorišćenju bakra kako bolji hidrodinamički uslovi flotiranja kao posledica veće stabilnosti i viskoziteta pulpe, tako i dodatno iskorišćenje bakra iz same flotacijske jalovine.

Rezultati laboratorijskih istraživanja i zaključci doneti na osnovu istih, potvrđeni su snimanjem industrijskog procesa

prerade topioničke šljake u RTB-u Bor, Srbija. Nezadovoljavajuća efikasnost klasifikacije u hidrociklonu definisana preko iskorišćenja obračunske klase krupnoće – 0,074 mm u prelivu od 60 %, kao i vrednost cirkulativne šarže od oko 750–950 % to najbolje potvrđuju. Zbog male stabilnosti pulpe i neodgovarajućeg hidrodinamizma iste u flotacionim mašinama, iskorišćenje bakra u procesu osnovnog flotiranja je takođe nezadovoljavajuća i iznosi oko 56 %.

Sadržaj obračunske klase krupnoće u pesku hidrociklona 6%.

Rezultati prikazanih i drugih istraživanja [2,8,9] bili su osnova za kreaciju idejnog rešenja nove tehnologije za zajedničku preradu topioničke šljake i stare flotacijske jalovine. Nova tehnologija zajedničke prerade dva tehnogena otpada, velika zagađivača životne sredine, prikazana je na slici 8.

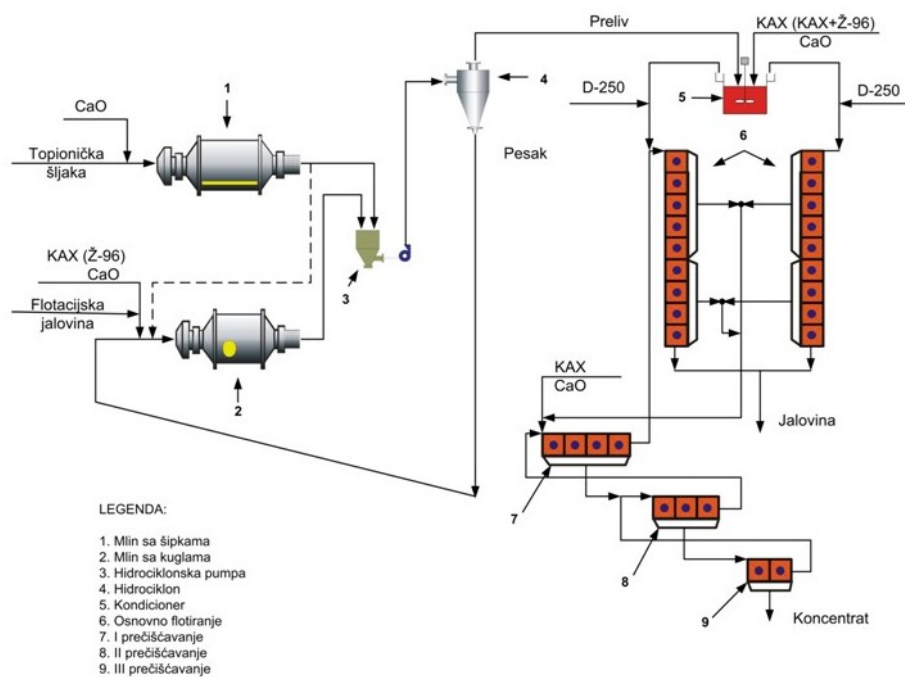

Sl. 8. Tehnološka šema zajedničke prerade topioničke šljake i flotacijske jalovine [2,8,9]

ZAKLJUČAK

Rezultati eksperimentalnih istraživanja pojedinih fenomena i pojava koji utiču na najznačajnije faze procesa topioničke šljake, potvrđuju naša teoretska razmatranja.

Na osnovu ostvarenih rezultata u laboratorijskim istraživanjima, a koji su prezentovani u radu, u industrijskim uslovima prerade topioničke šljake, primenom predložene tehnologije zajedničke prerade šljake i stare flotacijske jalovine, mogu se očekivati znatno bolji tehnokonomski pokazatelji procesa. Smanjenje potrošnje energije i čelika u industrijskom procesu mlevenja, i povećanje kapaciteta prerade, doprineli bi smanjenju troškova za oko 10 – 15 %, a povoljniji granulometrijski sastav proizvoda mlevenja i veća stabilnost pulpe u procesu flotiranja usloveli bi povećanje iskorišćenja za oko 15 %. Ostvareni efekti značajno bi uticali na povećanje ekonomičnosti prerade navedenih tehnogenih otpadnih sirovina, i učinili bi je ekonomski održivom.

LITERATURA

- [1] Z. Štirbanović, R. Stanojlović, J. Sokolović, D. Antić, Possibilities for Processing Technological Wastes from Copper Production in RTB Bor, Proceedings of 41st International October Conference on Mining and Metallurgy, ISBN 978-86-7827-033-8, 04-06 October 2009., Kladovo, Serbia, (2009), pp. 231-236.
- [2] R. Stanojlović, J. Sokolović, Z. Štirbanović, Contribution to Sustainability of Smelting Slag Processing in the Mining and Smelting Basin Bor (RTB Bor) by Improvements of Existent Technological Process, Proceedings of 40th International October Conference on Mining and Metallurgy, ISBN 978-86-80987-60-6, 05-08 October 2008., Sokobanja, Serbia, (2008), 46-50.
- [3] R. Stanojlović, Z. Štirbanović, J. Sokolović, D. Antić, Heterogeneity of Smelter Slag and Old Flotation Tailing - Aggravating Factors of Technological Efficiency, Proceedings of 41st International October Conference on Mining and Metallurgy, ISBN 978-86-7827-033-8, 04-06 October 2009., Kladovo, Serbia, (2009), 361-368.
- [4] H. Shen, E. Forsberg, An Overview of Recovery of Metals from Slags, Waste Management 23 (2003) 933-949
- [5] H. Alter, The Composition and Environmental Hazard of Copper Slags in the Context of the Basel Convention, Resources, Conservation and Recycling 43 (2005), 353-360.
- [6] C. Shi, C. Meyer, A. Behnood, Utilization of Copper Slag in Cement and Concrete, Resources, Conservation and Recycling 52 (2008), 1115-1120.
- [7] I. Alp, H. Deveci, H. Sungun, Utilization of Flotation Wastes of Copper Slag as Raw Material in Cement Production, Journal of Hazardous Materials 159 (2008), 390-395.

- [8] R. Stanojlović, Z. Štirbanović, Z. S. Marković, J. Sokolović, D. Antić, Possibilities for Improving Technological Indicators of Smelter Slag Froth Flotation Process, Proceedings of 21st International Serbian Symposium of Mineral Processing, ISBN 978-86-80987-63-7, 04-06 November 2008., Bor, Serbia, (2008), pp. 271-277.
- [9] R. Stanojlović, Z. Štirbanović, J. Sokolović: Primena nove tehnologije u funkciji održive prerade topioničke šljake RTB-a Bor, Reciklaža i održivi razvoj 1 (2) (2008) 34-42

UDK: 622.7:666.952:658.5671(045)=20

Rodoljub D. Stanojlović, Zoran M. Štirbanović*, Jovica M. Sokolović**

NEW TECHNOLOGICAL PROCEDURE FOR SUSTAINABLE PROCESSING OF MINING TECHNOLOGICAL WASTE**

Abstract

The results show technological possibility and economical feasibility for joint processing of two technological waste materials generated in the process of copper ore treatment. Smelter slag and flotation tailings from the Mining and Smelting Basin - RTB Bor, Serbia, are two technological waste materials stored on dumps and emerging permanently. They represent the major polluters of the environment, but also the potential raw material resources, according to the content of useful components. Due to the specific physical, chemical and mineralogical characteristics, individual processing of these waste materials do not guarantee a profitable business. Joint processing of smelter slag and old flotation tailings, in mass ratio 90% of slag and 10% of flotation tailings, in the original process technology, increases recovery of copper in the flotation process for approximately 15%, efficiency of grinding and classification processes are also increasing, thereby power consumption is reduced 10 -15%, making the processing of these waste materials to have both the positive economic and ecological effect.

Key words: *smelter slag, flotation tailings, technological wastes, flotation, copper recovery*

INTRODUCTION

Mining and Smelting Basin RTB Bor, produces dozens of different polluting, technological waste materials in complex technologies of copper production, from exploitation to the electrolytic refining [1]. A number of them, in gaseous, liquid or

* *University of Belgrade, Technical Faculty in Bor,
Department of Mineral and Recycling Technologies*

** *This paper presents the results of the Projects TR 33038 "Improving the Technology of Copper Ore Mining and Processing with Monitoring of Living and Working Environment in RTB Bor Group", and TR 33007, "Implementation of Modern Technical-technological and Environmental Solutions in the Existing Production Systems of the Copper Mine Bor and Copper Mine Majdanpek", funded by Ministry of Education and Science of the Republic of Serbia. The authors grateful to the said Ministry.*

solid form, contain significant concentrations of useful components, which could be valorized using the modern technologies. The research results of processing the smelter slag, the most common waste in copper metallurgy, indicate the possibility of technological processing [2,3]. Due to the increased resistance to comminution, increased density and lack of aluminates [4-7], the formed pulp from smelter slag has the reduced viscosity and stability. These characteristics of smelter slag and pulp, formed from slag condition, have caused the rapid sedimentation of the solid, which negatively affects the efficiency of the most important processes, grinding and classification, as well as the process of flotation concentration. Increased energy consumption in grinding process, i.e. increased processing costs and reduced recovery of useful components in the flotation process have called a question to the economy of this technological waste processing.

Researches to improve viscosity and stability of the pulp, by adding flotation tailings in the process of grinding slag should yield the positive results. The use of flotation tailings, the most common technological waste and also the biggest polluter in the process of copper ore processing, will improve the pulp characteristics, and thus the efficiency of the most important phases of the process. Thanks to lesser density of flotation tailings, and the presence of fine particles of aluminates and aluminosilicates, the pulp formed from 90% of slag and 10% of tailings, has the increased viscosity and stability which creates higher efficiency and lower power consumption in the processes of grinding and classification, and also increased recovery of useful components in the flotation process. Increased recovery of copper from mixture of smelter slag and flotation tailings could be the result of higher recovery of copper from slag because of

better hydrodynamic conditions of flotation, and also recovery of copper from flotation tailings. Higher pulp viscosity has the positive effect on grinding efficiency in the ball mill, due to better adhering of material on grinding balls. Increased efficiency of hydraulic classification in hydrocyclones, as the result of higher pulp stability, reduces the unnecessary circulation of enough comminuted particles for the flotation process, through hydrocyclone underflow to regrinding in the ball mill.

Reducing the circulative charge to the optimal limit, i.e. reducing the share of enough grained particles in the hydrocyclone underflow, has multiple technical and economic importance. Besides increasing capacity and reducing energy consumption in the grinding process, less over grinding of useful components particles causes their better recovery in the flotation process.

The positive effects of applying the new technology for common processing of smelter slag and flotation tailings, expressed through reduction of processing costs and increased recovery of useful components, allow a profitable activity and economic sustainability of the environment.

EXPERIMENTAL PART

Experimental studies were carried out in two phases. The first phase was aimed to determine the characteristics of smelter slag and flotation tailings and the pulp formed from these materials, which are significant for intended processing procedures. In the second phase, parallel experiments of flotation concentration of copper from smelter slag, and mixtures of slag and flotation tailings, were carried out. The results should be verified by previous theoretical considerations of technological feasibility the common processing of these technological waste materials.

Smelter Slag Characteristics

For selected process of copper concentration from smelter slag, the flotation concentration, the mineralogical and chemical compositions of materials have particular importance.

Microscopic and mineralogical studies were carried out on microscope Carl Zeiss-Jena "JENAPOL-U". The results of these studies are shown in Table 1.

Chemical analysis of the samples was carried out using different analytical methods (Table 2).

Table 1. Mineralogical composition of smelter slag

Minerals	Content (%)
Fayalite	60.00
Magnetite	30.00
Bornite	6.50
Chalcopyrite	1.50
Metallic copper	0.50
Copper matte	0.30
Chrysocolla	0.15
Covellite	0.05
Pyrite	1.00
Σ	100.00

Table 2. Chemical composition of smelter slag

Element Compound	Content (%)	Analytical method
Fe _Σ	37.05	VT
SiO ₂	32.77	G
Fe ₃ O ₄	9.68	A-Fe 304
Al ₂ O ₃	4.86	ICP-AES
Fe in Fe ₂ O ₃	3.02	R
S	0.81	G
Ca	3.21	AAS
Mg	0.62	AAS
Cu _Σ	0.84	SF
Cu _{elem}	0.38	G
Cu _{sul}	0.30	R
Cu _{ox}	0.16	PO
Ag	3.3 g/t	FA
Au	0.5 g/t	FA

Mineralogical and chemical compositions of smelter slag confirm the possibility of use the flotation concentration as the method for concentration of useful components. The contents of copper 0.84% and precious metals, gold 0.5 g/t and silver 3.3 g/t, confirms the statement that this technological waste contains 2-3 times higher concentration of these useful components comparing to their contents in the primary copper ores which are now exploited (0,25 - 0,35% Cu). This fact indicates that this technological waste represents the raw material resource and justifies the research possibilities for its processing.

Density of smelter slag is approximately 3500 kg/m³. The fact that density of this technological waste is about 500-700 kg/m³ higher than density of copper ore leads to a conclusion that the sedimentation rate of slag particles in the pulp is higher compared to the sedimentation rate of copper ore particles of the same size.

Grindability, i.e. the resistance to comminution, grinding kinetics and grain size composition are physical characteristics of the material that largely influence the processing costs.

Bond's work index in the ball mill for smelter slag is $W_i = 31$ kWh/t, what is about two times higher comparing to the copper ore. This fact points out to the expected high energy consumption in the grinding process. Diagrams in Figure 1 show the grinding kinetics for smelter slag and copper ore. It can be seen that much longer time is needed for grinding the smelter slag compared to copper ore, in order to achieve the same fineness of grinding products.

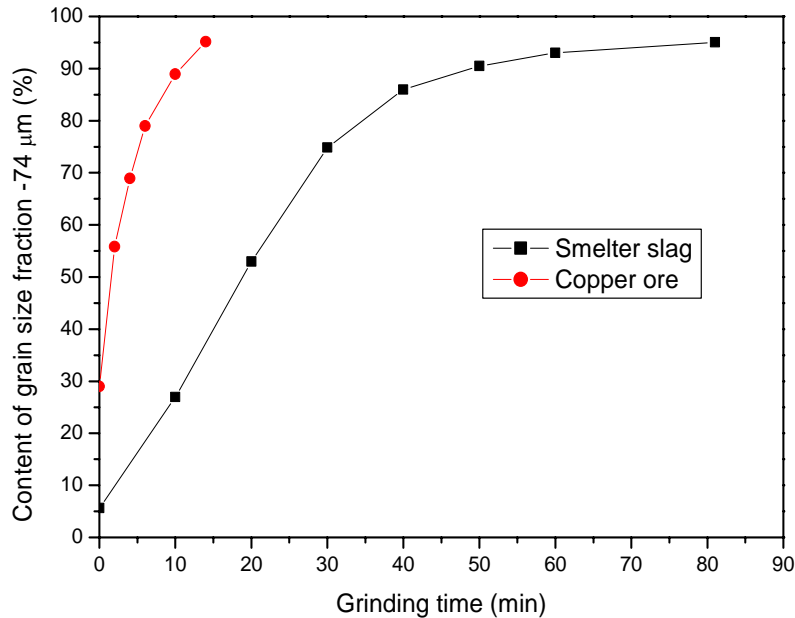

Fig. 1. Efficiency of grinding smelter slag and copper ore

The research results clearly indicate the high resistance to comminution of this technological waste that confirms the previous observation of high energy consumption in the process of fragmentation and, hence, the increased processing costs.

Flotation Tailings Characteristics

Studies were performed on the “old” flotation tailings produced in the process of copper ore flotation in the first half of the last century. This technological waste material was chosen due to the increased content of useful components, 0.15 – 0.4% Cu, caused by high content of copper in the ore that was processed in that period (2.5-3% Cu), as well as the efficiency of flotation concentration technology, applied at that time.

Mineralogical compositions of samples from the old flotation tailings from different depths of the old flotation tailing dump are shown in Table 3, and the chemical

composition of samples from different parts of dump, characteristic for the flotation process, are shown in Table 4.

Table 3. Mineralogical composition of samples from the old flotation tailings

Minerals	Content (%)	
	Sample 1 (0-16 m)	Sample 2 (16-40 m)
Chalcopyrite	0.16	0.12
Covellite	0.03	0.11
Enargite	0.01	0.02
Chalcocite	0.01	0.01
Bornite	in traces	0.01
Azurite	in traces	0.03
Cuprite	0.01	0.04
Pyrite	14.27	22.20
Tailings minerals	80.63	71.96
Other minerals	4.88	5.50
Σ	100.00	100.00

Table 4. Chemical composition of samples from the old flotation tailing [3]

Element Component	Dam of flotation tailing dump	Inside of flotation tailing dump	Analytical method
	Content (%) (g/t)*	Content (%) (g/t)*	
Cu ₂	0.155	0.370	SF
Cu _{ox}	0.033	0.120	PO
Cu _{sol}	0.122	0.250	R
S	9.870	12.260	G
Fe	8.860	10.270	VT
SiO ₂	58.030	59.710	G
Al ₂ O ₃	12.040	12.630	ICP-AES
Au	0.300*	0.600	FA
Ag	2.140*	1.300	FA

The results show that flotation tailings contain the significant concentrations of useful components in mineralogical form suitable for use in the flotation process.

Table 5. Density values of samples of the old flotation tailings [3]

Flotation tailings	Sample 1 (dam of flotation tailing dump)	Sample 2 (central part of flotation tailing dump)	Sample 3 (peripheral part of flotation tailing dump)	Composite sample
ρ (kg/m ³)	2 650	3 070	2 814	2 844

Much lower density of flotation tailings from the density of smelter slag is caused by different mineralogical and chemical composition. While in the smelter slag, the ferrosilicates with higher densities (3700-3900 kg/m³) have dominant participation, then aluminum silicates with significantly lower densities (2500-2600 kg/m³) have the highest participation in the flotation tailings.

However, according to the basic reason for using the flotation tailings in the process of smelter slag processing, to improve the characteristics of the pulp, i.e. to increase the viscosity and stability to the optimal value, the physical characteristics of this technological waste have a great importance.

Density of flotation tailings was determined on a number of samples taken from different places of the flotation tailing dump. The need of taking samples from different places of the flotation tailing dump, from dam to its beach, was caused by the way of formation the flotation tailing dump and distribution of hydrocyclone overflow and underflow. Density value of individual samples as well as the mean density of flotation tailings, used in further researches, is given in Table 5.

Resistance to the comminution of fine-grained flotation tailings material is not possible to determine by the standard Bond's method; however, the same can be identified with resistance to the comminution of the primary copper ore, that was 10-15 kWh/t for processed ore in that period.

Diagrams in Figure 2 show the comparative value of grinding kinetics of two types of technological waste.

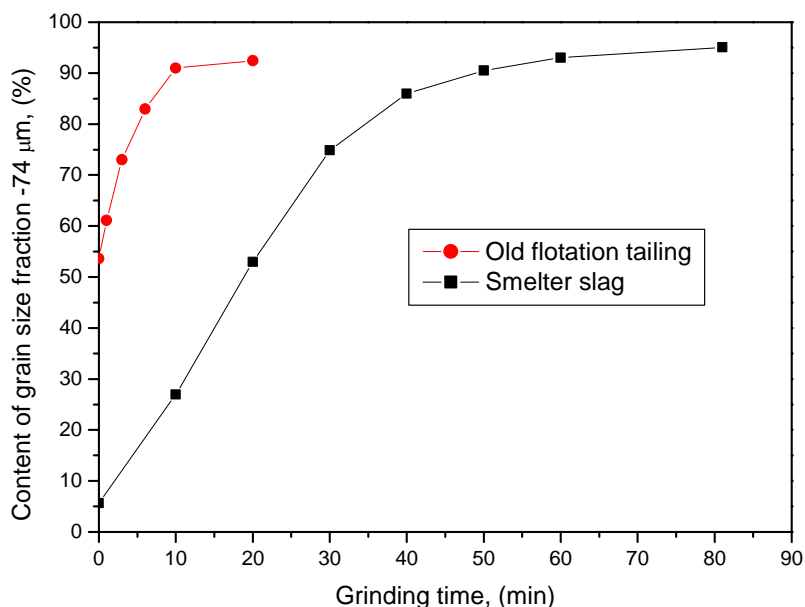

Figure 2. Efficiency of grinding smelter slag and old flotation tailings

Much shorter time, required to achieve the certain fineness of flotation tailing grinding product in relation to the required time to achieve the same fineness of grinding smelter slag, points out to a logical conclusion on expected better grindability of these two types of technological waste mixture in relation to the grindability of pure smelter slag.

EXPERIMENTS OF GRINDING THE SMELTER SLAG AND MIXTURE OF SLAG AND FLOTATION TAILINGS

Grindability study was done by the wet grinding method in a ball mill. In the first phase of the study, three series of laboratory experiments were carried out: on smelter slag and mixture of slag and old flotation tailing in the certain mass ratios, with the aim of defining the grinding efficiency of individual samples.

The second phase of study was aimed to investigate the effect of pulp density, or solid/liquid ratio on the efficiency of grinding process in the ball mill. Experiments were carried out on smelter slag, as well as mixtures of slag and old flotation tailing.

The used equipment in experiments

Experiments were carried out in a laboratory mill, type “Denver”, with the following technical and technological conditions:

- Characteristics of the mill
 - Mill capacity: 13.8 l
 - Charge mass: 10.5 kg
 - Speed: 56 min⁻¹
 - Mill size: DXL = 370x130 mm
 - Grain size distribution of grinding balls charge (Table 6.)

Table 6. Grain size composition of charge of grinding balls

Coarseness of balls (mm)	Mass (%)	D (%)
+50	15.30	100.00
-50+40	43.99	84.70
-40+30	27.64	40.71
-30+0	13.07	13.07
	100.00	-

- Characteristics of raw materials
 - Crushed smelter slag – 3.327 mm
 - Flotation tailings – 0.833 mm with percentage participatio of 5% and 10%

Technological regime of laboratory grinding experiments

All experiments were carried out at predefined regime of grinding:

- Mass of solid, $m = 1.0$ kg
- Solid content in the pulp in the first phase of the study, $p = 75\%$
- Solid content in the pulp in the second phase of the study, $p = 70-80\%$
- Coefficient of mill charging with ball charge, $\varphi = 15\%$

Research results

The efficiency of grinding smelter slag and mixture of slag and old flotation tailings in defined mass ratio is shown in the diagrams in Figure 3.

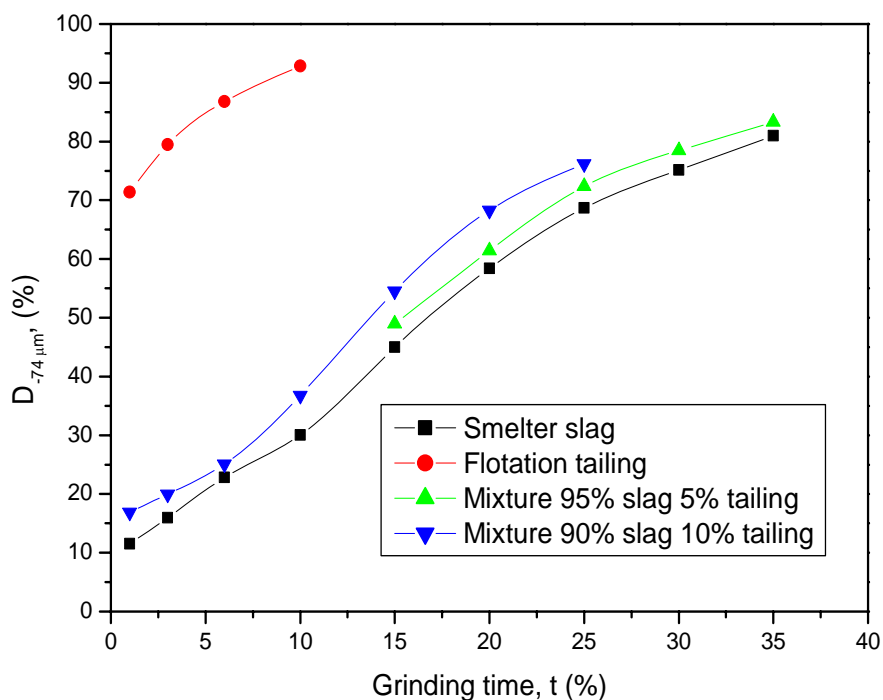

Figure 3. Efficiency of grinding raw materials in ball mill

Diagram in Figure 4 shows the dependence of grinding efficiency in the ball mill on pulp density, or solid/liquid ratio

in grinding the smelter slag and mixture of slag and old flotation tailings for 20 minutes.

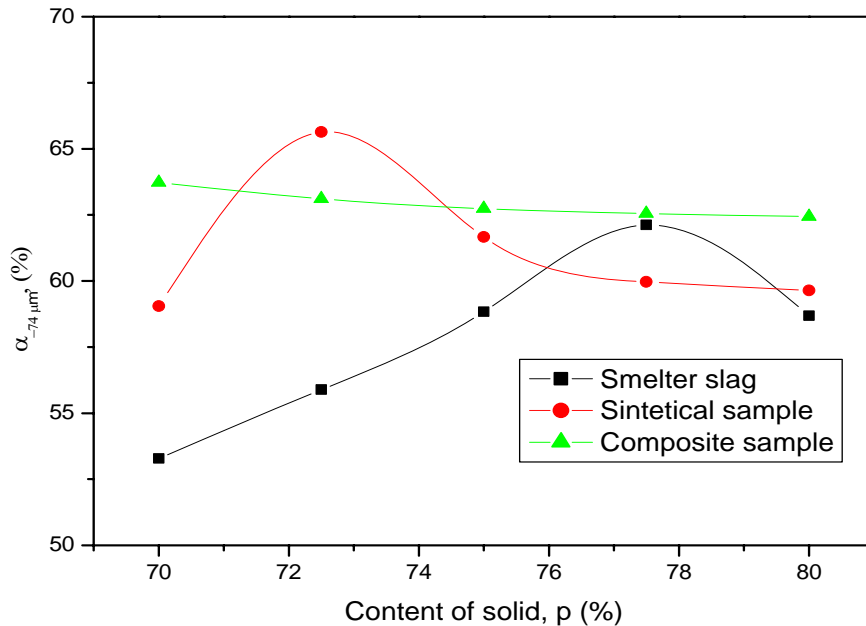

Figure 4. Efficiency of grinding the raw materials in the function of pulp density

Study results on the efficiency of grinding smelter slag and mixture of slag and flotation tailings in different mass ratios, Figure 3, show the positive impact of flotation tailings, or presence of aluminates, on better grinding efficiency. In order to achieve 60% of grain size fraction – 0.074 mm in the grinding product of slag and flotation tailing mixture, 7% less grinding time is needed for mixture 95% of slag and 5% of tailings, and 18% for mixture 90% of slag and 10% of tailings, compared to the required time for only smelter slag grinding, which made the adequate energy savings. Different impact of solid content in the pulp, as well as various values of the same indicator at

which the best effects of grinding smelter slag and mixture of slag and flotation tailings are achieved, confirm the conclusion on the positive impact of aluminates on grinding efficiency.

EXPERIMENTS OF DETERMINING THE PULP STABILITY

Investigations the impact of flotation tailings on stability of formed pulp from smelter slag were carried out by parallel measurements of deposition rate, i.e. the height of deposited solid phase, in the formed pulp from smelter slag and mixtures of slag and flotation tailings in different mass ratios.

The used equipment in experiments

Experiments were carried out on identical equipment, including a glass measuring cylinder of 1000 ml and a mechanical stirrer, type TECHNIQUE ŽELEZNIKI UM 405.

Technological regime of experiments

Experiments were carried out at room temperature of 20°C, on samples with same grinding product fineness, 60% of grain size fraction – 0.074 mm, and with

30% of solid phase in the pulp, with a constant rate of stirrer, 1000 rpm, and pH value of the pulp of 8.

Experimental results

Experimental results of deposition rate of solid phase in the formed pulp from smelter slag and mixture of slag and flotation tailings in different mass ratios are shown on diagrams in Figure 5.

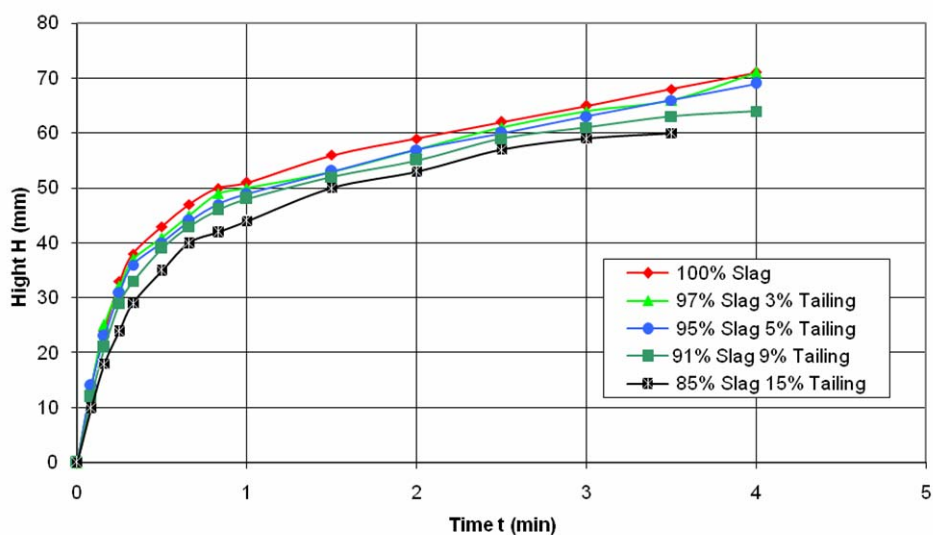

Figure 5. Dependence of the height of formed deposit on deposition time in the formed pulp from smelter slag, with and without addition of flotation tailings

Due to a specificity of flotation process that requires a solid phase in the pulp in dispersed state, i.e. to provide hydrodynamic conditions that disable the sedimentation of solid phase, the experiments of determining the stability of formed pulp from smelter slag and mixture of slag flotation tailings were carried out measuring the amount of deposited solid phase in the function of deposition time. Research results, shown on diagrams in Figure 5, unambiguously confirm the theoretical assumption that the presence of flotation tailings, or fine-ground aluminates and aluminosilicates in the formed pulp from smelter slag will increase its stability. Increasing the time required to settle down the same amount of solid phase in all intervals and all deposited amounts of solid phase in the static conditions of sedimentation process, with certainty confirm the positive impact of flotation tailings on the pulp stability.

Expected consequences of this phenomenon are primarily higher efficiency in the process of hydraulic classification in hydrocyclones and flotation concentration with all positive effects, described above.

FLOTATION EXPERIMENTS

Research of flotation concentration of copper from smelter slag was carried out in five series of laboratory experiments.

Laboratory flotation concentration experiments were carried on a smelter slag sample and four samples of mixture of slag and old flotation tailings in different

mass relations, with the same, previously determined optimal technological regime.

The used equipment in experiments

Flotation experiments were conducted in laboratory flotation machine, type DENVER DR-12, with 2.6 l volume of a cell. Impeller rate of the rotor was 1600 rpm, and the volume of added air 260 l/min or 4.33 l/s.

Control of pH was performed by pH meter, type MA 5705, Iskra Kranj, with a combined electrode, type SENTIX 50.

Technological regime of flotation experiments

Technological capabilities for mutual processing of technological wastes, smelter slag and flotation tailings, can be confirmed by the results of concentration of useful components from them, kinetics of flotation process and technological recovery of useful components.

The effect of flotation tailings impact on indicators of technological process of smelter slag flotation will be viewed by comparison the results of parallel laboratory experiments of flotation smelter slag and mixture of slag and flotation tailings, in different mass ratios, with identical flow sheet and regime of flotation.

The flow sheet and regime of laboratory experiments of basic flotation, shown in Figure 6, were defined based on extensive research of optimization the process parameters.

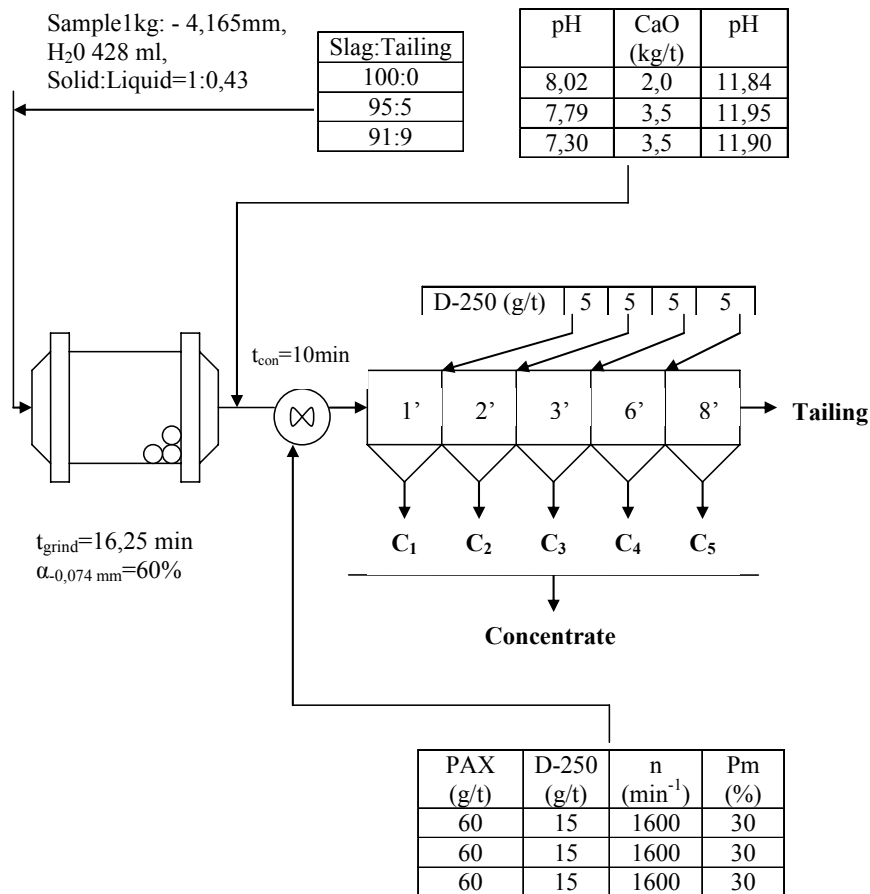

Figure 6. Flow sheet of flotation experiments

Research results

Diagrams in Figure 7 show the kinetics of copper flotation concentration from smelter slag and mixture of slag and flota-

tion tailings in different mass ratios for each laboratory experiment separately.

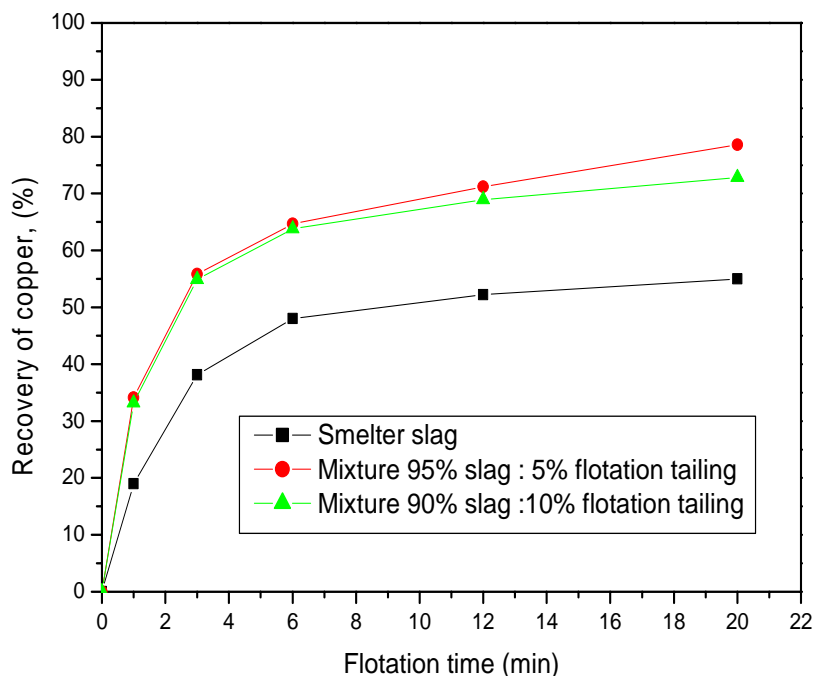

Figure 7. Flotation kinetics of smelter slag and mixture of slag and flotation tailings

Testing results of copper flotation kinetics from smelter slag and mixture of slag and flotation tailing, shown in Figure 7, confirm the positive impact of stability and viscosity of pulp on copper recovery. The difference in copper recovery for approximately 17%, i.e. 24%, for the flotation experiment lasting 20 minutes, were beyond expectations. It is necessary to point out that the cause of increased copper recovery are better hydrodynamic flotation conditions as the result of higher pulp viscosity and stability, as well as additional copper recovery from flotation tailings.

The results of laboratory testing and conclusions, based on them, were confirmed observing the industrial process of smelter slag processing in RTB Bor, Serbia. Unsatisfactory, the efficiency of cla-

ssification in hydrocyclones, defined by recovery of grain size fraction – 0.074 mm in hydrocyclone overflow of 60% and the value of circulative charge of approximately 750-950%, confirm this. Due to poor pulp stability and its inadequate hydrodynamics in the flotation machines, copper recovery in the basic flotation process was also unsatisfactory, approximately 56%.

Content of grain size fraction – 0.074 mm in hydrocyclone underflow was 6%.

Present results and other studies [2, 8, 9] were basis for development the conceptual design for the new technology for mutual processing of smelter slag and old flotation tailings. The new technology for mutual processing two types of technological waste, large polluters, is shown in Figure 8.

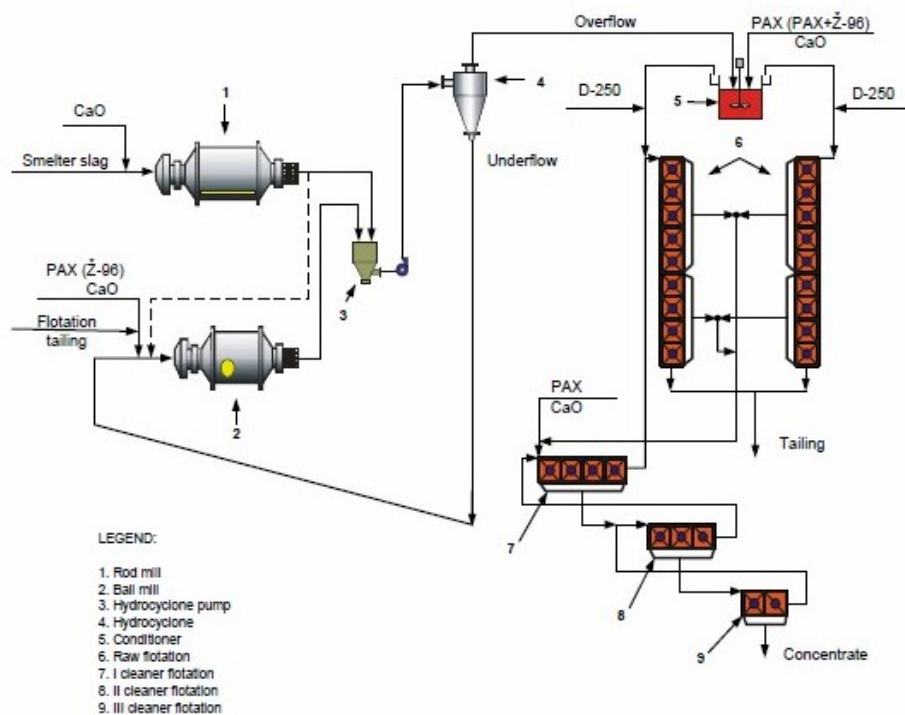

Figure 8. Technological flow sheet for mutual processing of smelter slag and old flotation tailings [2,8,9]

CONCLUSION

Results of experimental studies of specific phenomena, that affect the most important stages in the process of smelter slag flotation, confirm our theoretical considerations.

Based on the results of laboratory testing, presented in this paper, in the industrial conditions of smelter slag processing, much better techno-economic indicators of the process can be expected applying the proposed technology for mutual processing of slag and old flotation tailings. Reducing energy and steel

consumption in the industrial grinding process, and increasing the processing capacity, can contribute to the reduced costs by 10 - 15%, and more appropriate grain size fraction of grinding product, and increased stability of pulp in the flotation process could cause the increased recovery by 15%. The achieved effects would significantly affect decrease in costs of processing these technological waste materials and would do it economically viable.

REFERENCES

- [1] Z. Štirbanović, R. Stanojlović, J. Sokolović, D. Antić, Possibilities for Processing Technological Wastes from Copper Production in RTB Bor, Proceedings of 41st International October Conference on Mining and Metallurgy, ISBN 978-86-7827-033-8, 04-06 October 2009, Kladovo, Serbia, (2009), pp. 231-236.
- [2] R. Stanojlović, J. Sokolović, Z. Štirbanović, Contribution to Sustainability of Smelting Slag Processing in the Mining and Smelting Basin Bor (RTB Bor) by Improvements of Existent Technological Process, Proceedings of 40th International October Conference on Mining and Metallurgy, ISBN 978-86-80987-60-6, 05-08 October 2008, Sokobanja, Serbia, (2008), pp. 46-50.
- [3] R. Stanojlović, Z. Štirbanović, J. Sokolović, D. Antić, Heterogeneity of Smelter Slag and Old Flotation Tailings - Aggravating Factors of Technological Efficiency, Proceedings of 41st International October Conference on Mining and Metallurgy, ISBN 978-86-7827-033-8, 04-06 October 2009, Kladovo, Serbia, (2009), pp. 361-368.
- [4] H. Shen, E. Forssberg, An Overview of Recovery of Metals from Slags, Waste Management 23 (2003) 933-949
- [5] H. Alter, The Composition and Environmental Hazard of Copper Slags in the Context of the Basel Convention, Resources, Conservation and Recycling 43 (2005) 353-360
- [6] C. Shi, C. Meyer, A. Behnood, Utilization of Copper Slag in Cement and Concrete, Resources, Conservation and Recycling 52 (2008) 1115-1120
- [7] I. Alp, H. Deveci, H. Sungun, Utilization of Flotation Wastes of Copper Slag as Raw Material in Cement Production, Journal of Hazardous Materials 159 (2008) 390-395
- [8] R. Stanojlović, Z. Štirbanović, Z. S. Marković, J. Sokolović, D. Antić, Possibilities for Improving Technological Indicators of Smelter Slag Froth Flotation Process, Proceedings of 21st International Serbian Symposium of Mineral Processing, ISBN 978-86-80987-63-7, 04-06 November 2008, Bor, Serbia, (2008), pp. 271-277.
- [9] R. Stanojlović, Z. Štirbanović, J. Sokolović: The Use of New Technology in the Function of Sustainable Treatment of Smelting Slag in RTB Bor, Recycling and Sustainable Development, 1(2) (2008) 34-42 (in Serbian)